

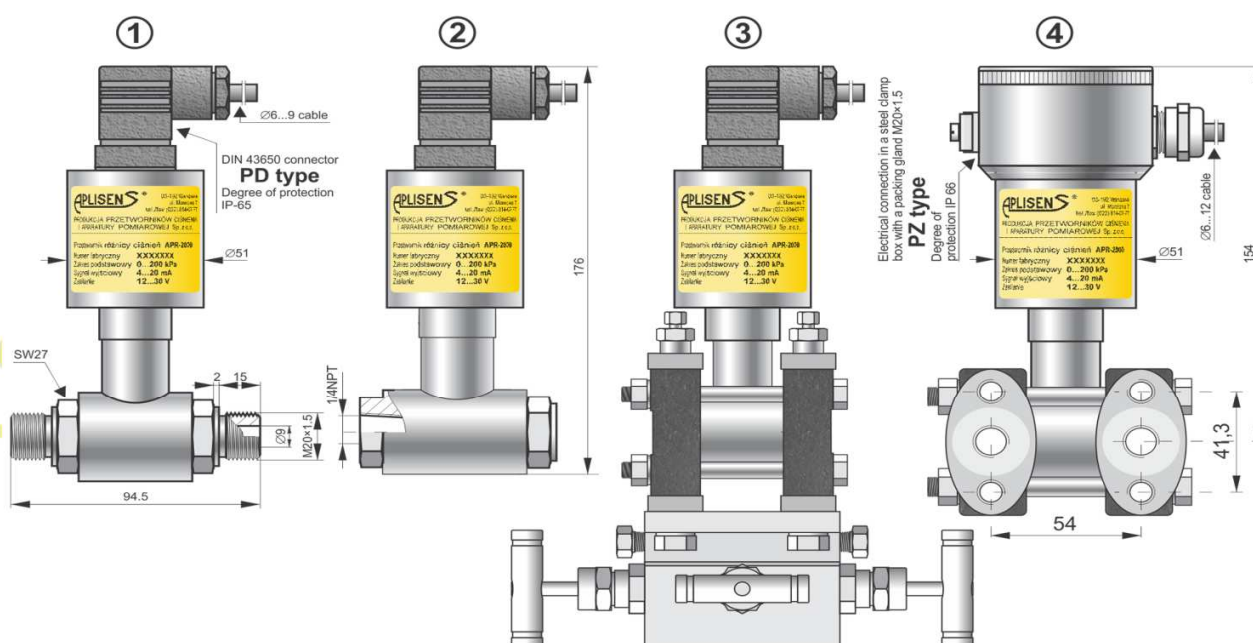

SMART DIFFERENTIAL PRESSURE TRANSMITTER APRE-2000



- ✓ 4...20 mA output signal + HART protocol
- ✓ ATEX Intrinsic safety
- ✓ Static pressure limit up to 420 bar
- ✓ Accuracy 0.1%
- ✓ Gold plated diaphragms (Au)
- ✓ Wetted parts material Hastelloy C276



- 1) Transmitter APRE-2000PD version with P type process connection; 2) Transmitter APRE-2000PD version with PN type process connection; 3) Transmitter APRE-2000PD – version with type C process connection rotated 90°; 4) Transmitter APRE-2000PD – version with type C process connection

Application and construction

The APRE-2000 transmitter is applicable to the measurement of differential pressure of gases, vapors and liquids. The active element is a piezoresistant silicon sensor separated from the medium by separating diaphragms and a specially selected type of manometric fluid. The special design of the active sensing element ensures that it is able to withstand pressure surges and overloads of up to 250, 320 or 420bar. Electronics in the casing with a degree of protection IP65, IP66.

Communication and configuration

The communication standard for data interchange with the transmitter is the HART protocol.

Communication with the transmitter is carried out with:

- ◆ a KAP-03 communicator,
- ◆ some other HART type communicators ,(□)
- ◆ a PC with the HA RT/USB/Bluetooth converter and Aplisens RAPORT 2 configuration software.

(□) .eddl files available on www.aplisens.com

The data interchange with the transmitter enables user to:

- ◆ identify the transmitter;
- ◆ configure the output parameters:
 - measurement units and values of the start and end-points of the measuring range;
 - damping time-constant;
 - conversion characteristic (inversion, user's non -linear characteristic);
- ◆ read the currently measured pressure value of the output current and the percentage output control level;
- ◆ force an output current with a set value;
- ◆ calibrate the transmitter in relation to model pressure.



Installation

The transmitter with **P type** process connection is not heavy, so it can be fitted directly onto impulse lines. For fitting in any desired position on a A25 pipe an Aplisens mounting bracket (**Fi 25 mounting bracket**, see page IV/ 5) is recommended.

The version with **C type** process connections can be fitted directly to a 3- or 5-valve manifold. We recommend factory-mounted transmitters with VM type valve manifold (see page IV/ 2). A transmitter without a valve manifold can be fitted in any position on a 2 " pipe or on a wall using the **C-2" mounting bracket** (see page IV/ 5).

When the special process connections are required for the level measurement of media in closed tanks (e.g. in the sugar and chemical industries) the transmitter is fitted with an Aplisens diaphragm seal. Sets of differential pressure transmitters with diaphragm seals are described in detail presented in the further part of the catalogue.

Measuring ranges

No.	Nominal measuring range (FSO)		Minimum set range		Rangeability	Overpressure limit/ static pressure limit
1	0...70 bar	(0...7 MPa)	7 bar	(700 kPa)	10:1	exception: 70 bar for P type
2	0...16 bar	(0...1,6 MPa)	1,6 bar	(160 kPa)	10:1	C-type: 250 / 320 / 420 bar (250 bar for PED version) P-type: 40 bar
3	0...2,5 bar	(0...250 kPa)	0,2 bar	(20 kPa)	12,5:1	
4	0...1 bar □	(0...100 kPa)	50 mbar	(5k Pa)	20:1	
5	0...0,25 bar □	(0...25 kPa)	10 mbar	(1k Pa)	25:1	
6	-0,5...0,5 bar □	(-50...50 kPa)	0,1 bar	(10 kPa)	10:1	
7	-100...100 mbar □	(-10...10 kPa)	10 mbar	(1 kPa)	20:1	
8	-5...70 mbar □	(-0,5...7 kPa)	4 mbar	(0,4 kPa)	18:1	C-type: 200 bar (10 bar for PED version) P-type: 40bar
9	-25...25 mbar □	(-2,5...2,5 kPa)	2 mbar	(0,2 kPa)	25:1	
10	-7...7 mbar □□	(-700...700 Pa)	1 mbar	(0,1 kPa)	14:1	

□ available also in HS version
□□ available only in HS version;

Technical data

Metrological parameters

Accuracy $\Delta \pm 0,1\%$ of calibrated range
Long term stability Δ accuracy for 3 years
 (for the nominal measuring range) $\Delta 2 \times$ accuracy for 5 years
 HS version: Δ accuracy for 6 years
Thermal error $< \pm 0,08\%$ (FSO) / 10°C
 max. $\pm 0,3\%$ (FSO) in the whole compensation range
Thermal compensation range -25...80°C
Zero shift error for static pressure
 0,01% (FSO) / 10 bar for range no. 3, 4, 5, 6, 7, 8
 0,03% (FSO) / 10 bar for range no. 1, 2
 0,08% (FSO) / 10 bar for range no. 10
 Zeroing the transmitter in conditions of static pressure can eliminate this error.
Response time 500ms
Additional electronic damping 0...60 s
Error due to supply voltage changes 0,002% (FSO) / V

Electrical parameters

Power supply 7,5...55 VDC (Ex ia 7,5...28 VDC)
Output signal 4...20 mA, two wire transmission
Load resistance $R[\Omega] \Delta \frac{U_{sup}[V] - 7,5V}{0,0225A}$
Resistance required for communication min. 240 Ω

Materials

Wetted parts type P, PN process connection: SS316L
 type P(H) process connection: SS316L or Hastelloy C276
 type C process connection: SS316L
Diaphragms SS316L, Hastelloy C 276, Au
Casing SS304

Operating conditions

Operating temperature range (ambient temp.) -25...85°C
 Exi a version -25...80°C

Medium temperature range -25...120°C
 over 120°C – measurement with use an impulse line or diaphragm seals
 up to 100°C - PED version

CAUTION: the medium must not be allowed to freeze in the impulse line or close to the process connection of the transmitter

Electrical diagram

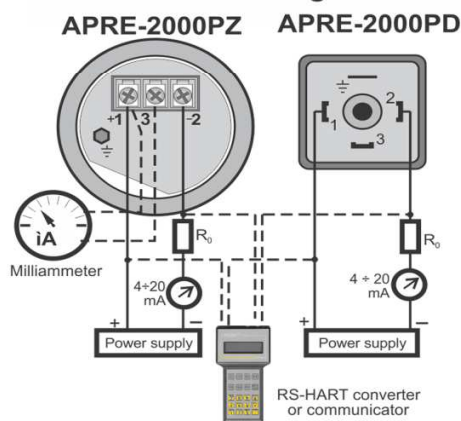

Accuracy depending on the set range

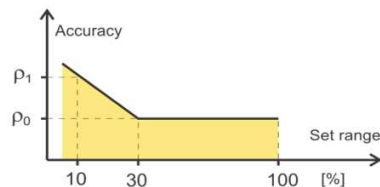

ρ_0 – error for nominal measuring range (0...100% FSO)
 ρ_1 – error for range 0...10% FSO
 $\rho_1 = 2 \times \rho_0$
 Numerical error values are given in the technical data under metrological parameters



Ordering procedure

Model	Code	Description																						
APRE-2000		Smart differential pressure transmitter																						
Casing, output signal, electrical connection	/PD..... /PZ.....	Housing IP65 with DIN43650 connector, without display, output 4-20mA + Hart 304SS housing, IP66, without display, output 4-20mA + Hart																						
Versions, certificates more than one option is available	/Exia..... /PED..... /HS..... /Tlen..... /320 bar..... /420 bar.....	<div style="border: 1px solid black; padding: 2px; width: fit-content;"> II 1/2G Ex ia IIC T4/T5/T6 Ga/Gb II 1 D Ex ia IIC T110°C Da I M1 Ex ia I Ma </div> Exia for HS version available from 2016 European Pressure Equipment Directive N° 97/23/EC, category IV Ultra stable version (only ranges no. 4+10) For oxygen service (sensor filled with Fluorolube fluid) Static pressure 320 bar, only for C process connection, not available in PED version Static pressure 420 bar, only for C process connection, not available in PED version																						
Nominal measuring range	/0+70 bar..... /0+16 bar..... /0+2,5 bar..... /0+1 bar..... /0+0,25 bar..... /-0,5+0,5 bar..... /-0,1+0,1 bar..... /-5+70mabr..... /-25+25mbar..... /-7+7mbar.....	<table border="1" style="width: 100%; border-collapse: collapse;"> <thead> <tr> <th>Range</th> <th>Min. set range</th> </tr> </thead> <tbody> <tr> <td>0+70 bar (0+7000 kPa)</td> <td>7bar (700 kPa)</td> </tr> <tr> <td>0+16 bar (0+1600 kPa)</td> <td>1,6bar (160 kPa)</td> </tr> <tr> <td>0+2,5 bar (0+250 kPa)</td> <td>0,2bar (20 kPa)</td> </tr> <tr> <td>0+1 bar (0+100 kPa)</td> <td>50mbar (5 kPa)</td> </tr> <tr> <td>0+0,25 bar (0+25 kPa)</td> <td>10mbar (1 kPa)</td> </tr> <tr> <td>-0,5+0,5 bar (50+50 kPa)</td> <td>0,1bar (10 kPa)</td> </tr> <tr> <td>-0,1+0,1 bar (-10+10 kPa)</td> <td>10mbar (1 kPa)</td> </tr> <tr> <td>-5+70 mbar (0,5+7 kPa)</td> <td>4mbar (0,4 kPa)</td> </tr> <tr> <td>-25+25 mbar (-2,5+2,5 kPa)</td> <td>2 mbar (0,2 kPa)</td> </tr> <tr> <td>-7+7 mbar (-0,7+0,7 kPa)</td> <td>1 mbar (0,1 kPa)</td> </tr> </tbody> </table>	Range	Min. set range	0+70 bar (0+7000 kPa)	7bar (700 kPa)	0+16 bar (0+1600 kPa)	1,6bar (160 kPa)	0+2,5 bar (0+250 kPa)	0,2bar (20 kPa)	0+1 bar (0+100 kPa)	50mbar (5 kPa)	0+0,25 bar (0+25 kPa)	10mbar (1 kPa)	-0,5+0,5 bar (50+50 kPa)	0,1bar (10 kPa)	-0,1+0,1 bar (-10+10 kPa)	10mbar (1 kPa)	-5+70 mbar (0,5+7 kPa)	4mbar (0,4 kPa)	-25+25 mbar (-2,5+2,5 kPa)	2 mbar (0,2 kPa)	-7+7 mbar (-0,7+0,7 kPa)	1 mbar (0,1 kPa)
Range	Min. set range																							
0+70 bar (0+7000 kPa)	7bar (700 kPa)																							
0+16 bar (0+1600 kPa)	1,6bar (160 kPa)																							
0+2,5 bar (0+250 kPa)	0,2bar (20 kPa)																							
0+1 bar (0+100 kPa)	50mbar (5 kPa)																							
0+0,25 bar (0+25 kPa)	10mbar (1 kPa)																							
-0,5+0,5 bar (50+50 kPa)	0,1bar (10 kPa)																							
-0,1+0,1 bar (-10+10 kPa)	10mbar (1 kPa)																							
-5+70 mbar (0,5+7 kPa)	4mbar (0,4 kPa)																							
-25+25 mbar (-2,5+2,5 kPa)	2 mbar (0,2 kPa)																							
-7+7 mbar (-0,7+0,7 kPa)	1 mbar (0,1 kPa)																							
Measuring set range	/...+... [required units]	Calibrated range in relation to 4mA and 20mA output																						
Process connections	/C..... /CR..... /P..... /PN..... /code of diaphragm seal.....	Thread 1/4NPT F on the cover flanges cover flanges material SS316. Allows mounting with a valve manifold. Process connection of cover flange: M10 (option /C(7/16) - 7/16UNF) C-type process connection rotated 90° Thread M20x1,5 (male) Thread 1/4"NPT (female) Diaphragm seal (see chapter of diaphragm seals) mounted on Hi side of transmitter, Lo side 1/4NPT Female																						
Material of diaphragms (refers only to C, CR, P, PN process connection)	(without marking)..... /(H)..... /(Au).....	Diaphragms material SS316L Diaphragms material Hastelloy C276 (/P and /PN – all wetted parts in Hastelloy C276 on request) (not available for transmitters in HS version) Gold plated diaphragms (not available for transmitters in HS version)																						
Gasket (refers only to C, CR process connection)	(without marking)..... /NBR..... /PTFE.....	FPM Viton NBR (for oxygen service) PTFE																						
Electrical connection	(without marking) /US.....	Packing gland M20x1,5 Thread 1/2"NPT Female																						
Accessories	/C-2"..... /C-2"(SS)..... /FI25..... /RedSpaw P..... /RedSpaw C..... /Red d/P 1/2"...	Mounting bracket for 2" pipe (to C process conn.), mat. zincd steel Mounting bracket for 2" pipe (to C process conn.), mat. Stainless Steel Mounting bracket for 2" pipe (to P process conn.), mat. Stainless Steel Connector to weld impulse pipes dia. 12 and 14 mm, material 15HM(SO) or SS316(S). Only process connection P type Connector to weld impulse pipes dia. 12 and 14 mm, material 15HM. Only process connection C type. Adapter for differential pressure transmitters with C type process connection, output thread 1/2NPT F. Material SS316L																						
Other specification	/.....	Description of required parameters																						

Example 1: Differential pressure transmitter, output 4..20mA + HART, version Ex ia, static pressure 320bar, nominal measuring range 0..2bar, calibrated range 0..1,6bar, process connection C, stainless steel housing, mounting bracket for 2" pipe

APRE-2000PZ/Exia/320bar/0..2bar/0..1,6bar/C/C-2"

Example 2: Differential pressure transmitter, output 4..20mA + HART, nominal measuring range 0..1bar, calibrated range 0..1bar, process connection flange diaphragm seal DN80PN40, electrical connection with DIN43650 connector.

APRE-2000PD/0..1bar/0..1bar/S-P DN80

Note: Differential pressure transmitter APRE-2000 with two diaphragm seals is offered as a model APRE-2200ALW.